

User Manual

ControlPlex[®] Controller CPC12EC



1 Table of contents

1	Table of contents	2
2	General information	4
2.1	Safety instructions	4
2.2	Qualified personnel	4
2.3	Use	4
2.4	Delivery state	4
3	General description	5
3.1	Design of the entire system	6
3.2	Dimensions CPC12xx-Tx	7
3.3	Status indication and terminals	7
3.3.1	Terminals for voltage supply	8
3.3.2	EtherCAT interfaces with integral switch, connection sleeve XF1 (IN), XF2 (OUT)	8
3.3.3	ETHERNET interface, connection sleeve X1	8
3.3.4	LED status indication	9
4	Mounting and installation	9
4.1	Mounting of the system	9
5	Operating modes of the CPC12 bus controller	10
5.1	Operating mode: Start-up mode	10
5.2	Operating mode: System error mode	10
5.3	Operating mode: Configuration error mode	10
5.4	Operating mode: Stand-alone mode	10
5.5	Operating mode: Slave mode	10
5.5	Operating mode: Firmware Update Mode	10
6	Basic functions of the entire system	11
6.1	Internal cycle times	11
6.2	Hot swap of circuit protectors	11
6.3	About the additional Ethernet interface	11
6.3.1	Web Server	11
6.3.2	Default IP address -X1	11
6.3.3	User name and password	11
6.3.4	OPC UA	11
6.3.5	MQTT	11

7	Communication via EtherCAT	12
7.1	ControlPlex® device model	12
7.2	ESI file	16
8	Cyclical I/O data	16
8.1	Cyclical data CPC12 controller	16
8.1.1	I/O data CPC12 controller	16
8.1.2	Total current CPC12 controller	16
8.2	Cyclical data of circuit protectors	17
8.2.2	Cyclical input data of circuit protectors	17
8.2.3	Cyclical output data of circuit protectors	18
9	Non-cyclical data	19
9.1	CPC12 controller	20
9.1.1	Device information CPC12 controller	20
9.1.2	Configuration data CPC12 controller	21
9.1.3	Action commands CPC12 controller	22
9.1.4	Dynamic information CPC12 controller	23
9.2	Circuit protectors/channels	23
9.2.1	Device parameters for one channel	23
9.2.2	Device information for one channel	24
9.2.3	Configuration data for one channel	25
9.2.4	Event message for one channel	25
9.2.5	Action commands for one channel	26
9.2.6	Diagnostic data for one channel	27
10	Appendix	29
10.1	List of pictures	29
10.2	Technical data	29
10.3	Subject index	29

2 General information

2.1 Safety instructions

This manual points out possible danger for your personal safety and gives instruction how to avoid property damage. The following safety symbols are used to draw the reader's attention to the safety instructions included in this manual.



Danger!

Danger to life and limb unless the following safety precautions are taken.



Warning!

Danger to machinery, materials or the environment unless the following safety precautions are taken.



Note!

Information is provided to allow a better understanding.



Caution

Electrostatically sensitive devices (ESD). Devices must exclusively be opened by the manufacturer.



Disposal guidelines

Packaging can be recycled and should generally be brought to re-use.

2.2 Qualified personnel

This user manual must exclusively be used by qualified personnel, who are able – based on their training and experience – to realise arising problems when handling the product and to avoid related hazards. These persons have to ensure that the use of the product described here meets the safety requirements as well as the requirements of the presently valid directives, standards and laws.

2.3 Use

The product is part of a continuous enhancement process. Therefore there might be deviations between the product in hand and this documentation. These deviations will be remedied by a regular review and resulting corrections in future editions. The right to make changes without notice is reserved. Error and omissions excepted.

2.4 Delivery state

The product is supplied with a defined hardware and software configuration. Any changes in excess of the documented options are not permitted and lead to liability exclusion.

3 General description

The customers' demands for a constant quality of the produced goods, while at the same time increasing the quantities, pose great challenges to the mechanical and plant engineering industry. At the same time, globalisation is creating worldwide value flows and production chains. Machines and plants that had still been regionally organised just a few years ago are now networked worldwide. These developments extend the requirements of machine and plant control as well as of the installed components. An ever growing number of measuring data need to be recorded, analysed, evaluated and saved. This increases the transparency of the manufacturing process and thus system availability.

The DC 24 V power distribution is also affected by this development. The control voltage supplies all essential components of the machine or system. These include, besides programmable control units, for example actuators and sensors. Therefore, the control voltage has a special importance in the entire production process. Its availability and stability is crucial for system availability and quality of the produced goods. The REX system meets these requirements. It consists of electronic circuit protectors which are connected with each other via an integral connector arm without requiring additional components. Power supply is via the EM12 supply module which can supply the circuit protectors with max. 40 A. The new CPC12 bus controller additionally allows access to all

system-relevant data of the superordinate control systems. This can be via the the EtherCAT interface as well as via an additional Ethernet interface.

The CPC12 connects the circuit protectors with the superordinate control unit. Its internal ELBus® interface realises the connection with the REX intelligent circuit protectors¹. The CPC12 allows entire access on all required parameters of the electronic circuit protectors, their control unit and the visualisation of the device data.

This is made available at the field bus interface for the superordinate control unit and also at the third RJ45 interface for further connection. Thus the system offers a fully parameterisable protection of the DC 24 V circuits and ensures selective overcurrent protection of sensors and actuators, decentralised peripheral sub-assemblies etc. and their supply lines.

¹ To simplify presentation and explanation, the naming of intelligent circuit breakers is limited to the system designation REX. This designation includes the REX12D and REX22D circuit breakers.

3.1 Design of the entire system

The CPC12 bus controller is the centre piece of the **ControlPlex®** system. It allows consistent communication between the electronic circuit protectors and the superordinate control level, connected HMIs and even into the Cloud.

The EtherCAT interface to the superordinate control unit is implemented as two RJ45 connectors. It allows connection of the required control unit with the **ControlPlex®** system. This enables display, analysis as well as diagnosis of the individual measuring values. In addition, it allows control of the individual electronic circuit protectors. An additional Ethernet interface enables direct access of the integral web server of the bus controller. Service staff can thus directly access the system on site. Moreover, access via the connected infrastructure of the company is enabled and thus global access. OPC UA and MQTT allow transmission of all measuring values and status

information independently of the control system, e.g. to a superordinate cloud application. Revised measuring values of all electronic circuit protectors are also forwarded to the automation system. This enables the user to have unrestricted access to the safety-relevant functions even in the event of an interruption. Any occurring failures will be detected quickly and can be remedied without delay. The **ControlPlex®** system effectively reduces system downtimes and significantly increases the productivity.

The CPC12 bus controller allows connection of up to 16 double channel electronic circuit protectors:

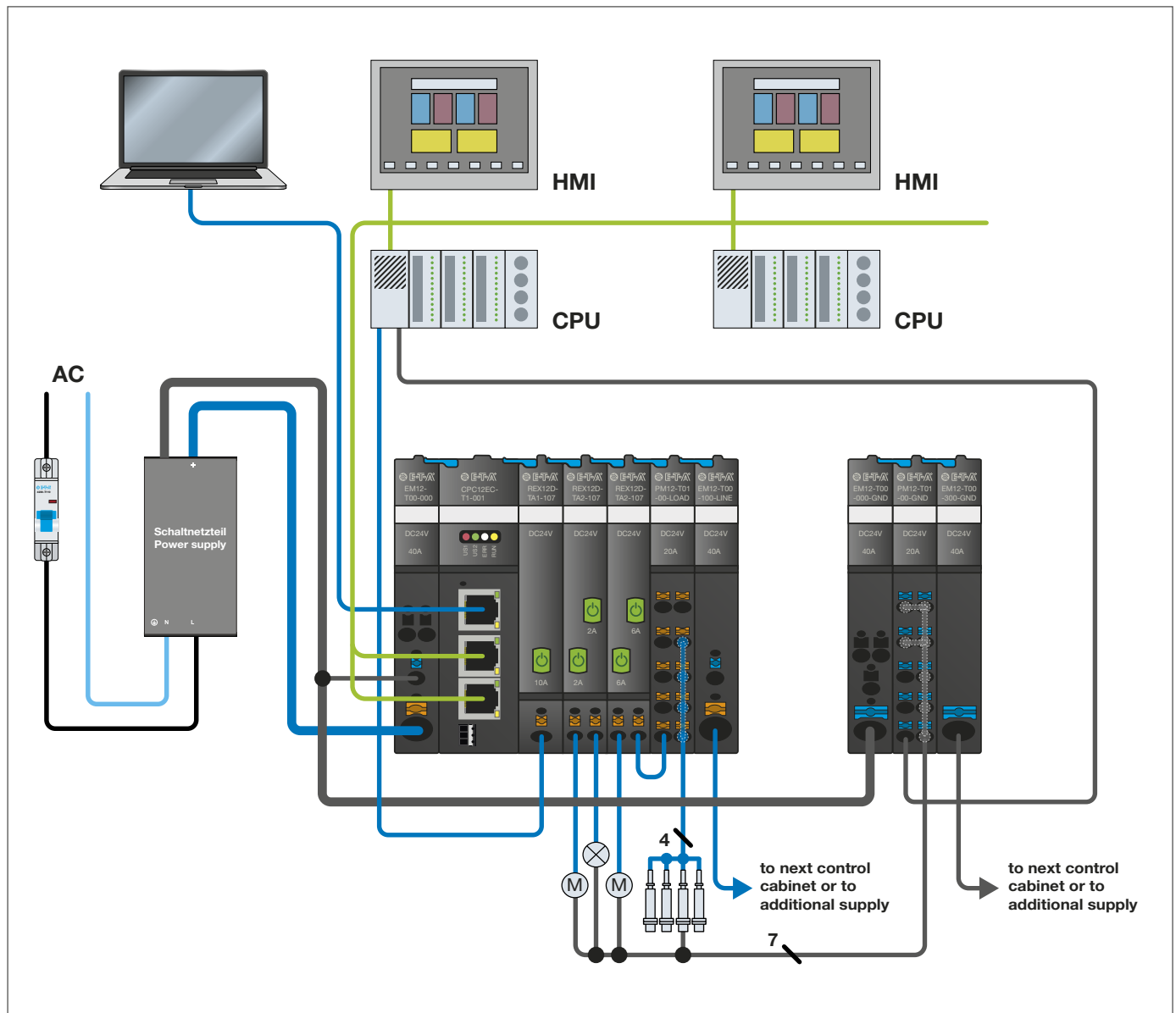

fig. 1: System overview

3.2 Dimensions CPC12xx-Tx

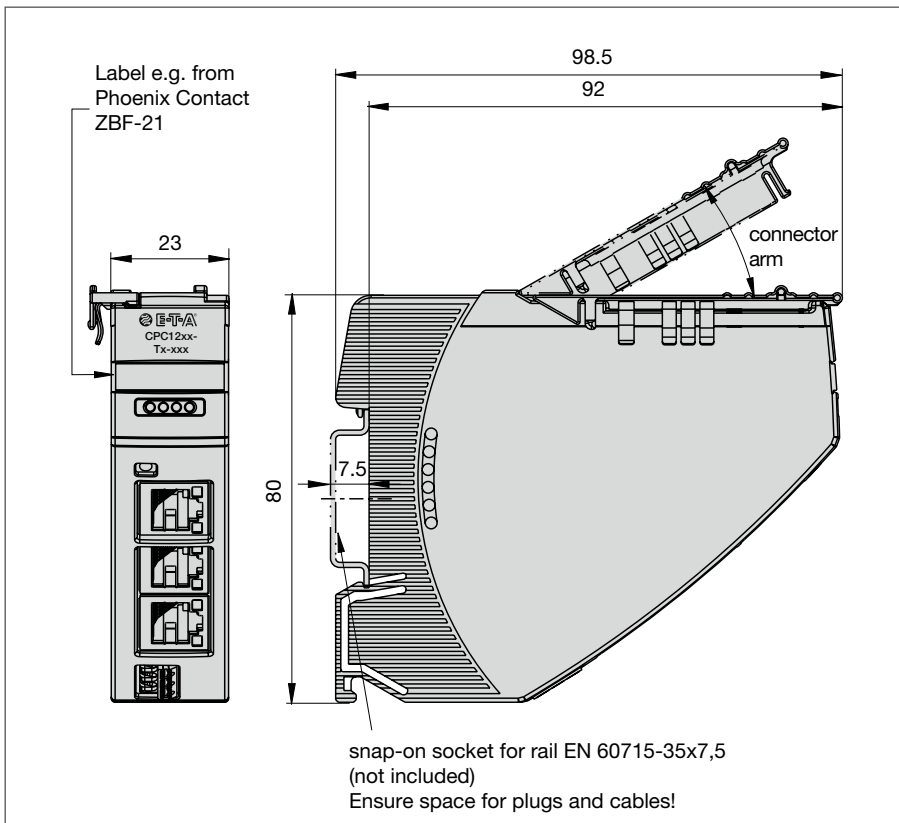

fig. 2: Dimensions CPC12

3.3 Status indication and terminals

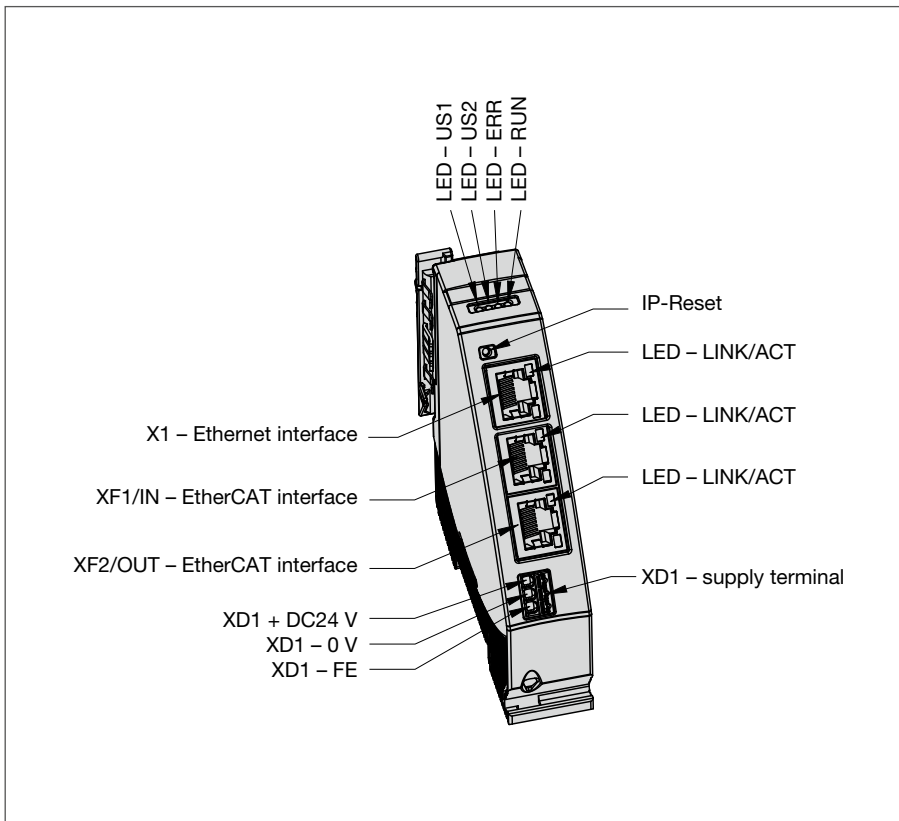

fig. 3: Status indication and terminals CPC12EC

3.3.1 Terminals for voltage supply

Supply XD1

Rated voltage: DC 24 V($\pm 5\%$ 18 ... 30 V)

Rated current: typically 75 mA

Terminal design: 3 x push-in terminals (+0V/ FE)

max. cable cross section	rigid 0.2 – 1.5 mm ²
flexible with wire end ferrule (without plastic sleeve)	0.2 – 1.5 mm ²
flexible with wire end ferrule (with plastic sleeve)	0.2 – 0.75 mm ²
cable cross section	AWG24 – AWG16 str.
stripping length	8 mm



Using a supply voltage outside the indicated operating range can cause malfunctions or destruction of the device.



The voltage supply of the CPC12 bus controller is guaranteed via the supply module and the related connector arm. The use of the line terminals is optional.

3.3.2 EtherCAT interfaces with integral switch, connection sleeve XF1 (IN), XF2 (OUT)

XF1 Connection to bus system EtherCAT

Type: RJ45

When wiring and connecting to the EtherCAT bus system, the installation guideline (ETG.1600) of the EtherCAT Technology Group must be observed.

XF2 Connection to bus system EtherCAT

Type: RJ45

When wiring and connecting to the EtherCAT bus system, the installation guideline (ETG.1600) of the EtherCAT Technology Group must be observed.

3.3.3 ETHERNET interface, connection sleeve X1

X1 Connection with the bus controller CPC12 and the integral web server

Type: RJ45

3.3.4 LED status indication

Visual status indication by means of multicoloured LED

Operating mode	Indication of operating mode			
	LED US1	LED US2	LED ERR	LED RUN
EtherCAT Init-State	n.a.	n.a.	n.a.	off
EtherCAT Pre-Operational-State	n.a.	n.a.	n.a.	green blinking (0.2 s on / 0.2 s off)
EtherCAT Safe-Operational-State	n.a.	n.a.	n.a.	green blinking (0.2 s on / 0.2 s off)
EtherCAT Operational-State	n.a.	n.a.	n.a.	green
EtherCAT error	n.a.	n.a.	red	n.a.
No EtherCAT error	n.a.	n.a.	off	n.a.
Voltage supply OK+	green	n.a.	n.a.	n.a.
Firmware update	off	off	off	off
Actuator voltage ok	n.a.	green	n.a.	n.a.
No actuator voltage	n.a.	red	n.a.	n.a.
No connected device or bus error	n.a.	orange blinking (0.5 s on / 0.5 s off)	n.a.	n.a.

fig. 4: Display status LEDs

n.a. = not applicable

Visual signalling of RJ45 interfaces

LED-LINK/ACT

Operating mode	Indication of operating mode
Link available	green
No link available	off
Act available	green blinking

fig. 5: Display LEDs RJ45 connectors

4 Mounting and installation

4.1 Mounting of the system

The preferred mounting position of the **ControlPlex®** system is horizontal.

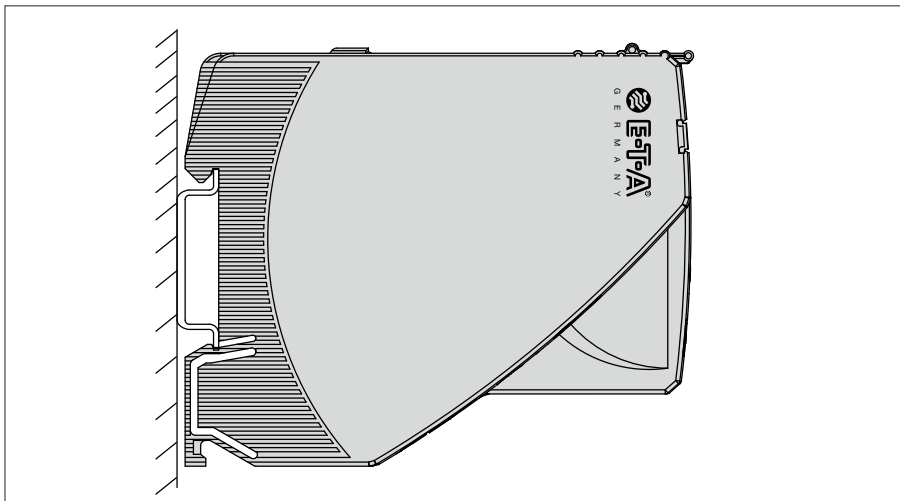

fig. 6: Installation drawing

5 Operating modes of the CPC12 bus controller

5.1 Operating mode: Start-up mode

The CPC12 bus controller is initialised by applying the supply voltage. The device will carry out internal programme memory tests and self test routines. During this time a communication via the interfaces is not possible.

5.2 Operating mode: System error mode

If a failure is detected during the self test routines, the bus controller will change into operating mode System Error. This operating mode can only be discontinued by way of re-starting the device and it prevents the data exchange via the interfaces. If the bus controller is in this operating mode, it is unable to control the electronic circuit protectors and these will stay in the stand-alone mode (overcurrent protection).

5.3 Operating mode: Configuration error mode

If there are no valid or invalid configuration data available in the bus controller, it will change into this operating mode. This operating mode only allows non-cyclical data exchange. Cyclical data exchange is prevented. Leave this operating mode upon receipt of the correct slot parameters and configuration data.

5.4 Operating mode: Stand-alone mode

In this operating mode there is no connection between the bus controller and the superordinate control unit. In this case the CPC12 bus controller will automatically adopt the control and parameterisation of the electronic circuit protectors, because all required data sets are saved within the CPC20. By means of the web server, the electronic circuit protectors, their status and parameters can be accessed via the Ethernet interface interface. It is thus possible to change e.g. parameter data of the various electronic circuit protectors. After connection is built up to the superordinate control unit, this operating mode will be left and the control unit will take over control again as master. If during this time a parameter was changed while there was no communication, this will be signalled to the superordinate control unit. In this case the user can correspondingly define the control behaviour and it can be programmed in the programmable control unit. This allows the user to select a reaction meeting his requirements.

5.5 Operating mode: Slave mode

In this operating mode, the CPC12 bus controller is involved in an EtherCAT system. Communication to the CPC12 bus controller works faultlessly and the controller can be addressed and controlled by the superordinate control unit. Should the communication fail, this has no influence on the protective function of the circuit protectors. The behaviour of the bus controller with simultaneous use of a field bus interface and of the web server interface can be determined by means of the configuration of the device in the superordinate control unit.

It can be pre-selected there that Ethernet interface or the Web Server are granted either only reader access or reader and editor access. In the event of editor access, changes of the parameterisation of the electronic circuit protectors can be carried out in parallel to the field bus system. These parameter changes will then be advised to the superordinate control system and can be adopted by it or also overwritten. The user can select the behaviour accordingly.

5.5 Operating mode: Firmware Update Mode

The devices are supplied with a software programmed according to their functionality. If the functions of the devices are extended, they will be added by firmware update. It is therefore necessary to carry out a firmware update if the new functionality shall be used.

6 Basic functions of the entire system

6.1 Internal cycle times

The cycle time of the system depends on the number of electronic circuit protectors connected and on the internal baud rate. The internal baud rate can be 9600 or 19200 baud. The baud rate is only changed to 19200 when all connected circuit protectors support this function. The baud rate is signalled in the cyclical data in the »Status Controller«. The current cycle time can be retrieved with the non-cyclical access to the »dynamic information of the CPC12«.

The cycle time in the event of 16 circuit protectors and an internal baud rate of 9600 baud is approx. 480 ms for the cyclical data, i.e. 30 ms per unit. A window of 130 ms is kept free for non-cyclical data. In total, this is a max. cycle time of 610 ms.

An internal baud rate of 19200 baud reduces the cycle time for the cyclical data to some 240 ms, i.e. 15 ms per unit. A window of 100 ms is kept free for non-cyclical data. In total, this is a max. cycle time of 340 ms.

6.2 Hot swap of circuit protectors

If a new circuit protector is added to an existing application, it will automatically be parameterised with the available parameters for address slot. Transmission of the parameters will be without interruption of the cyclical data exchange between the CPC and the electronic circuit protector.

6.3 About the additional Ethernet interface

The additional Ethernet interface extends the functional scope of the bus controller. The following functionalities are provided via this interface.

6.3.1 Web Server

The web server offers the entire scope of measuring data, status information, parameterisation options and control function of the CPC12 bus controller. The parameterisation of the interface is described separately.

6.3.2 Default IP address -X1

The default IP address of the CPC12 is: 192.168.1.1 The web server can be reached via this IP address. By pressing the IP reset button for 3 seconds, the IP address is reset to the default value.

6.3.3 User name and password

In order to be able to carry out configurations, the user has to have the required access authorisation. It is defined in user administration.

The default settings are:

User	admin
Password:	admin



We urgently recommend to individually adjust these settings upon startup of the device.

6.3.4 OPC UA

This functionality will only be included and described in a later version.

6.3.5 MQTT

This functionality will only be included and described in a later version.

7 Communication via EtherCAT

7.1 ControlPlex® device model

The power distribution system with CPC12 controller consists of a passive supply module EM12-T00-000-DC24V-40A and up to 16 intelligent circuit protectors of the REX series.

The power distribution system **ControlPlex®** uses the following EtherCAT object list:

Index	Subindex	Name	Access	Data length	Data type
0x1000	–	Device Type	r	4 byte	integer
0x1008	–	Device Name	r		string
0x1009	–	Hardware Version	r		string
0x100A	–	Software version	r		string
0x1018	–	Identity Object	–	–	–
	0	Number of Entries	r	1 byte	integer
	1	Vendor ID	r	4 byte	integer
	2	Product Code	r	4 byte	integer
	3	Revision Number	r	4 byte	integer
	4	Serial Number	r	4 byte	integer
0x1600	–	Channel Control PDO	–	–	–
	0	Number of Entries	r	1 byte	integer
	1	Output Mapping Area 1	r	4 byte	integer
	2	Output Mapping Area 2	r	4 byte	integer
	3	Output Mapping Area 3	r	4 byte	integer
	4	Output Mapping Area 4	r	4 byte	integer
0x1A00	–	Channel status PDO	–	–	–
	0	Number of Entries	r	1 byte	integer
	1	Input Mapping Area 1	r	4 byte	integer
	2	Input Mapping Area 2	r	4 byte	integer
	3	Input Mapping Area 3	r	4 byte	integer
	4	Input Mapping Area 4	r	4 byte	integer
0x1A01	–	Channel Load Voltage PDO	–	–	–
	0	Number of Entries	r	1 byte	integer
	1	Input Mapping Area 1	r	4 byte	integer
	2	Input Mapping Area 2	r	4 byte	integer
	3	Input Mapping Area 3	r	4 byte	integer
	4	Input Mapping Area 4	r	4 byte	integer

⋮

Index	Subindex	Name	Access	Data length	Data type
0x1A02	–	Channel Load Current PDO	–	–	–
	0	Number of Entries	r	1 byte	integer
	1	Input Mapping Area 1	r	4 byte	integer
	2	Input Mapping Area 2	r	4 byte	integer
	3	Input Mapping Area 3	r	4 byte	integer
	4	Input Mapping Area 4	r	4 byte	integer
0x1AFF	–	Device Status PDO	–	–	–
	0	Number of Entries	r	1 byte	integer
	1	Status Mapping	r	4 byte	integer
	2	Total current mapping	r	4 byte	integer
0x1C00	–	Sync Manager Com.Type			–
	0	Number of Entries	r	1 byte	integer
	1	Subindex 001	r	1 byte	integer
	2	Subindex 002	r	1 byte	integer
	3	Subindex 003	r	1 byte	integer
	4	Subindex 004	r	1 byte	integer
0x1C12	–	Sync Manager 2 PDO Assignment	–	–	–
	0	Number of Entries	r	1 byte	integer
	1	Subindex 001	r	1 byte	integer
0x1C13	–	Sync Manager 3 PDO Assignment	–	–	integer
	0	Number of Entries	r	1 byte	integer
	1	Subindex 001	r	1 byte	integer
	2	Subindex 002	r	1 byte	integer
	3	Subindex 003	r	1 byte	integer
	4	Subindex 004	r	1 byte	integer
0x2100	–	Acyclic Data Controller	–	–	–
	0	Number of Entries	r	1 byte	integer
	1	System commands	w	1 byte	integer
	2	Configuration data controller	rw	8 byte	integer
	3	Device Information	r	19 byte	integer
	4	Dynamic Information	r	4 byte	integer

⋮

Index	Subindex	Name	Access	Data length	Data type
0x2101	–	Acyclic Data Ch1	–	–	–
	0	Number of Entries	r	1 byte	integer
	1	Parameter Channel	rw	2 byte	integer
	2	Device Information	r	19 byte	integer
	3	Device Type Config	rw	2 byte	integer
	4	Events	r	1 byte	integer
	5	Action Commands Channel	w	1 byte	integer
	6	Dynamic Information	r	22 byte	integer
0x2102	–	Acyclic Data CH2	–	–	–
	0	Number of Entries	r	1 byte	integer
	1	Parameter Channel	rw	2 byte	integer
	2	Device Information	r	19 byte	integer
	3	Device Type Config	rw	2 byte	integer
	4	Events	r	1 byte	integer
	5	Action Commands Channel	w	1 byte	integer
	6	Dynamic Information	r	22 byte	integer
...
0x2120	–	Acyclic Data CH32	–	–	–
	0	Number of Entries	r	1 byte	integer
	1	Parameter Channel	rw	2 byte	integer
	2	Device Information	r	19 byte	integer
	3	Device Type Config	rw	2 byte	integer
	4	Events	r	1 byte	integer
	5	Action Commands Channel	w	1 byte	integer
	6	Dynamic Information	r	22 byte	integer
0x6000	–	Channel status	–	–	–
	0	Number of Entries	r	1 byte	integer
	1	1.1 Status	r	1 byte	integer
	2	1.2 Status	r	1 byte	integer
	3	2.1 Status	r	1 byte	integer

	32	16.2 Status	r	1 byte	integer

⋮

Index	Subindex	Name	Access	Data length	Data type
0x6010	–	Channel Load Voltage	–	–	–
	0	Number of Entries	r	1 byte	integer
	1	1.1 Load Voltage	r	2 byte	integer
	2	1.2 Load Voltage	r	2 byte	integer
	3	2.1 Load Voltage	r	2 byte	integer

	32	16.2 Load Voltage	r	2 byte	integer
0x6020	–	Channel Load Current	–	–	–
	0	Number of Entries	r	1 byte	integer
	1	1.1 Load Current	r	2 byte	integer
	2	1.2 Load Current	r	2 byte	integer
	3	2.1 Load Current	r	2 byte	integer

	32	16.2 Load Current	r	2 byte	integer
0x7000	–	Channel Control	–	–	–
	0	Number of Entries	r	1 byte	integer
	1	1.1 Status	w	2 byte	integer
	2	1.2 Status	w	2 byte	integer
	3	2.1 Status	w	2 byte	integer

	32	16.2 Status	w	2 byte	integer
0xF000	–	Modular Device Profile	–	–	–
	0	Number of Entries	r	1 byte	integer
	1	Module Index Distance	r	2 byte	integer
	2	Maximum Number of Profiles	r	2 byte	integer
0xF030	–	Configured Module List	–	–	–
	0	Number of Entries	r	1 byte	integer
	1	Subindex 001	rw	2 byte	integer
0xF050	–	Detected Module List	–	–	–
	0	Number of Entries	r	1 byte	integer
	1	Subindex 001	r	2 byte	integer
0xF100	–	Controller Status	–	–	–
	0	Number of Entries	r	1 byte	integer
	1	Controller Status	r	2 byte	integer
0xF120	–	Total Current	–	–	–
	0	Number of Entries	r	1 byte	integer
	1	Total Current	r	4 byte	integer

fig. 7: EtherCAT object list

7.2 ESI file

The ESI file is in the download area of the E-T-A website and can be downloaded there.

8 Cyclical I/O data

Depending on the selected module, a varying number of data bytes are exchanged in the cyclical data traffic.

The ESI file made available for the projecting tool allows the related configuration, the system recognises all permitted configurations and processes the cyclical data defined in the projection.

The module I/O data CPC12 controller is firmly pre-set in slot 2 and cannot be removed because the input bytes hold vital failure and diagnostic information as described in the following.

8.1 Cyclical data CPC12 controller

The CPC12 controller cyclically provides status and total current information.

8.1.1 I/O data CPC12 controller

The 2 bytes of input data can be queried via register 0xF100 subindex 1. They hold the following global errors and diagnostic messages. This module holds 2 bytes output data which are meant for the later system extensions and which cannot currently be used.

	byte	type	range	description
Status controller	0 HighByte 1 LowByte	UInt16	0xFFFF	bit 0 = no configuration data available bit 1 = invalid configuration data bit 2 = Connected device type is not compatible to configuration bit 3 = reserve bit 4 = command buffer overflow bit 5 = no communication to ELBus [®] 1 bit 6 = reserve bit 7 = reserve bit 8 = reserve bit 9 = CPC temporary error bit 10 = CPC hardware error bit 11 = ELBus [®] 1 communication speed: 0=9600 Baud, 1=19200 Baud bit 12 = reserve bit 13 = reserve bit 14 = reserve bit 15 = writing access via web server deactivated = 1, allowed = 0

fig. 8: Cyclical diagnostic data CPC12

8.1.2 Total current CPC12 controller

Register 0xF120 subindex 1 contains the total current. A 16-bit value with the calculated total current of all circuit protectors entered in the slot (2 bytes input data) is made available.

The sub-module does not have output data.

The measuring value is indicated as follows:

	byte	type	range	description
Total current	0 HighByte 1 LowByte	UInt16	0 ... 65535	A standardised 16-bit-value with a resolution of 10 mA is made available. Example for calculation of the measuring value: value (1320)/100 $\hat{=}$ 13.20 Amps

fig. 9: Total current

8.2 Cyclical data of circuit protectors

The circuit protectors cyclically supply status, load voltage and load current information. The circuit protectors can additionally be controlled via cyclical output data.

Each circuit protector has up to two channels. The input and output data are always transmitted for both possible channels of a circuit protector. If the circuit protector used has only one channel, the status of the second channel is marked as not available (0xFF) and the load current and the load voltage are set to 0.

8.2.2 Cyclical input data of circuit protectors

10 bytes input data are provided per configured circuit protector. These consist of 1 byte status per channel and 2 bytes each load current and load voltage values per channel.

The status can be found under index 0x6000 from subindex 1 to 32.

The load voltage is in register 0x6010 from subindex 1 to 32.

The load current is in register 0x6020 from subindex 1 to 32.

The subindex represents the channel number.

Design of the input bytes per circuit protector is as follows:

	byte	type	range	description
Status channel	0	byte	0 ... 255	0xFF (255) $\hat{=}$ no device available or wrong device configured bit 0 = load output ON bit 1 = short circuit bit 2 = overload bit 3 = low voltage bit 4 = reserve bit 5 = reserve bit 6 = limit value current bit 7 = event »True« means the status is active.
Load current channel 1	1 HighByte 2 LowByte	UInt16	0 ... 65535	A standardised 16-bit-value with a resolution of 10 mA is made available. Example for calculation of the measuring value: value (150)/100 $\hat{=}$ 1.50 Amps
Load voltage channel 1	3 HighByte 4 LowByte	UInt16	0 ... 65535	A standardised 16-bit-value with a resolution of 10 mV is made available. Example for calculation of the measuring value: value (2512)/100 $\hat{=}$ 25.12 Volt
Status channel 2	5	byte	0 ... 255	0xFF (255) $\hat{=}$ no device available, wrong configuration or 1-channel device used or wrong device configured bit 0 = load output ON bit 1 = short circuit bit 2 = overload bit 3 = low voltage bit 4 = reserve bit 5 = reserve bit 6 = limit value current bit 7 = event »True« means the status is active.
Load current channel 2	6 HighByte 7 LowByte	UInt16	0 ... 65535	A standardised 16-bit-value with a resolution of 10 mA is made available. Example for calculation of the measuring value: value (150)/100 $\hat{=}$ 1.50 Amps
Load voltage channel 2	8 HighByte 9 LowByte	UInt16	0 ... 65535	A standardised 16-bit-value with a resolution of 10 mV is made available. Example for calculation of the measuring value: value (2512)/100 $\hat{=}$ 25.12 Volt

fig. 10: Input data circuit protector

8.2.3 Cyclical output data of circuit protectors

Each channel can be switched on or off or reset via the cyclical output data. A subindex (1 to 32) is reserved per channel in register 0x7000. The subindex again represents the channel number.

Design of the output bytes per circuit protector is as follows:

	byte	type	range	description
Control channel 1	0	byte	0 ... 255	bit 0 = load output ON/OFF bit 1 = reset load output (only responds to rising edge 0 -> 1) bit 2 = reserve bit 3 = reserve bit 4 = reserve bit 5 = reserve bit 6 = reserve bit 7 = reserve »True« means the status is active.
Control channel 2	1	byte	0 ... 255	bit 0 = load output ON/OFF bit 1 = reset load output (only responds to rising edge 0 -> 1) bit 2 = reserve bit 3 = reserve bit 4 = reserve bit 5 = reserve bit 6 = reserve bit 7 = reserve »True« means the status is active.

fig. 11: Output data circuit protector

9 Non-cyclical data

Non-cyclical services allow exchange of more data with the CPC12 controller and the circuit protectors. Access also allows direct addressing of a circuit protector. The index and subindex are used to read or write the CPC12 data. The access to the circuit protectors is divided into channels. Two channels are provided per circuit protector.

The non-cyclical access to the data of CPC12 is divided as follows:

Index	Subindex	Number of data bytes	Reading (R) / Writing (W)	Description
0x2100	03	19	R	Device information of CPC12 controller (see chapter 9.1.1).
0x2100	02	5	R/W	configuration data of CPC12 controller (see chapter 9.1.2).
0x2100	01	1	W	action commands for all channels and the CPC12 controller (see chapter 9.1.3).
0x2100	04	4	R	dynamic information of CPC12 controller (see chapter 9.1.4).

fig. 12: Division of parameter index CPC12

The non-cyclical access to the data of circuit protectors and/or channels is divided as follows:

Example index for channel 7, $0x2100 + 7 = 0x2107$

Index	Subindex	Number of data bytes	Reading (R) / Writing (W)	Description
0x2100 + number of channel	01	2	R/W	Device parameters of a channel (see chapter 9.2.1).
0x2100 + number of channel	02	19	R	device information of a channel (see chapter 9.2.2).
0x2100 + number of channel	03	2	R/W	configuration data of a channel (see chapter 9.2.3).
0x2100 + number of channel	04	1	R	event message of a channel (see chapter 9.2.4).
0x2100 + number of channel	05	1	W	action commands for a channel (see chapter 9.2.5).
0x2100 + number of channel	06	22	R	diagnosis data of a channel (see chapter 9.2.6).

fig. 13: Division of parameter index channel

9.1 CPC12 controller

The non-cyclical parameters of the controller are described in the following chapters.

9.1.1 Device information CPC12 controller

The device information of the controller consists of 19 bytes.

Access: Index 0x2100, subindex 3

All device information with possible conditions is described in the following table.

	byte	type	range	description
Circuit breaker p/n	0 HighByte 1 LowByte	UInt16	0 ... 65535	16437 = CPC12EC-T1 This list may be extended by future controllers.
Hardware version	2 HighByte 3 LowByte	UInt16	0 ... 65535	holds the hardware version of the installed product
Internal assembly order numbers	4 HwHb 5 HwLB 6 LwHB 7 LwLB	UInt32	0 ... 4294967295	holds the assembly order number of the installed product
Production facilities number	8 HwHb 9 HwLB 10 LwHB 11 LwLB	UInt32	0 ... 4294967295	holds the production facilities number of the installed product
Serial number	12 HwHb 13 HwLB 14 LwHB 15 LwLB	UInt32	0 ... 4294967295	holds the serial number of the installed product
Software version (major.x.x)	16	byte	0 ... 255	holds the major software version of the installed product
Software version (x.minor.x)	17	byte	0 ... 255	holds the minor software version of the installed product
Software version (x.x.build)	18	byte	0 ... 255	holds the build software version of the installed product

fig. 14: device information CPC12

9.1.2 Configuration data CPC12 controller

The device configuration data for the controller consists of 5 bytes.

Access: Index 0x2100, subindex 2

All configuration data with possible conditions are described in the following table.

	byte	type	range	description
Configuration data of the CPC	0	byte	0 ... 255	<p>bit 0 = writing via web server permitted. Allows changing of parameters via the server even when the bus connection is active.</p> <p>bit 1 True: In the event of a fieldbus interruption, the status of the load outputs is maintained. False: In the event a fieldbus interruption, all load outputs will be set to the status OFF.</p> <p>bit 2 = power saving mode, the LEDs will be dimmed for power reduction.</p> <p>bit 3 = reserve bit 4 = reserve bit 5 = reserve bit 6 = reserve bit 7 = reserve</p> <p>If not described otherwise, »True« means that the function is active.</p>
Control commands disable ELBus [®] 1 on CPC channel 1 ... 16	1 HighByte 2 LowByte	UInt16	0 ... 65535	<p>Each bit represents a channel. (bit 0 = channel 1; bit1 = channel 2 ...)</p> <p>If the bit is set, this means that the channel cannot be switched on or off via the control unit or the web server.</p>
Control commands disable ELBus [®] 1 on CPC channel 17 ... 32	3 HighByte 4 LowByte	UInt16	0 ... 65535	<p>Each bit represents a channel. (bit 0 = channel 17; bit1 = channel 18 ...)</p> <p>If the bit is set, this means that the channel cannot be switched on or off via the control unit or the web server.</p>
Reserve	5 HighByte 6 LowByte	UInt16	0	reserve
Reserve	7 HighByte 8 LowByte	UInt16	0	reserve

fig. 15: Configuration data CPC12

9.1.3 Action commands CPC12 Controller

The action commands of the controller consist of 1 byte. All action commands being sent to the CPC12 carry out the action for all channels.

Access: Index 0x2100, subindex 1

Action commands with possible conditions are described in the following table.

	byte	type	range	description
Action commands	0	byte	0 ... 255	116 = reset trip counter 118 = reset device parameters to factory settings including CPC12 ¹⁾ 131 = back to box ²⁾ 132 = Adjust device configuration to connected device type (cf. chapter 9.2.3) 192 = reset statistics minimum values 196 = reset statistics maximum values 220 = reset statistics mean values Other values will not be accepted.

fig. 16: Action commands CPC12

¹⁾ The command »118 = reset device parameters to factory settings including CPC12« within the action commands for the CPC12 shall reset the following data:

- parameters (current ratings = 10 A, limit value load current = 80 %) of each channel
- PLC lock bit of each channel (default = True, i.e. channel not to be controlled by the PLC)
- **not** the configured device types
- **not** the statistical values (min, max, avg) of the channels
- **not** the error memory, trip counter and trip reason of the channels
- configuration data
 - power saving mode = False = LEDs normal
 - behaviour of load outputs in the event of field bus interruption = True = status is preserved
 - writing via webserver allowed = True

²⁾ The command »131 = back-to-box« within the action commands for the CPC12 shall reset the following data:

- parameters (current ratings = 10 A, limit value load current = 80 %) of each channel
- PLC lock bit of each channel (default = True, i.e. channel not to be controlled by the PLC)
- configured device types (default = REX12D-TA1 = 0x9009 = 36873)
- statistical values (min, max, avg) of the channels
- the error memory, trip counter and trip reason of the channels
- configuration data
 - power saving mode = False = LEDs normal
 - behaviour of load outputs in the event of field bus interruption = True = status is preserved
 - writing via web server allowed = True
- IP configuration of the third ETH port X1
 - IP address = 192.168.1.1
 - network mask = 255.255.255.0
 - gateway = 192.168.1.254
 - DHCP = False
- user data
 - name = »admin«
 - password = »admin«

9.1.4 Dynamic information CPC12 controller

Access: Index 0x2100, subindex 4

	byte	type	range	description
Cycle time ELBus® 1	0 HighByte 1 LowByte	UInt16	0 ... 65535	Holds the internal cycle time of the ELBus® in milliseconds [ms].
Reserve	2 HighByte 3 LowByte	UInt16	0 ... 65535	reserve

fig. 17: Dynamic information CPC12

9.2 Circuit protectors/channels

The parameters of the circuit protectors are described in the following chapters. The parameters are organised in channels.

9.2.1 Device parameters for one channel

The device parameters for one channel consist of 2 bytes.

Access: Index 0x2100 + number of channel, subindex 1

All device parameters with possible conditions are described in the following table.

	byte	type	range	description
Rated current	0	byte	1 ... 25	Holds the current rating of the channel. With adjustable devices, you can set a new current rating here and transmit with a write command. 1 = 1A current rating 2 = 2A current rating 3 = 3A current rating ... 10 = 10A current rating (default value)
Limit value load current	6	byte	50 ... 100	Determines at which percentage of the current rating of a channel the limit value is exceeded. Exceedance is signalled with a bit in the »status channel« of the cyclical data. The range is from 50 % to 100 %. 100 %. The default value is 80 %.

fig. 18: Device parameters channel

9.2.2 Device information for one channel

The device information for one channel consists of 19 bytes.

Access: Index 0x2100 + number of channel, subindex 2

All device information with possible conditions is described in the following table.

	byte	type	range	description
Circuit breaker p/n	0 HighByte 1 LowByte	UInt16	0 ... 65535	36873 = REX12D-TA1-100 36874 = REX12D-TA2-100 36878 = REX12D-TE2-100 36910 = REX12D-TE2-100-CL2 36905 = REX12D-TB1-100 36937 = REX12D-TA1-100-CL2 36969 = REX12D-TB1-100-CL2 36906 = REX12D-TA2-100-CL2 36942 = REX12D-TE2-101 36974 = REX12D-TE2-101-CL2 37001 = REX12D-TA1-101 36938 = REX12D-TA2-101 37033 = REX12D-TB1-101 37065 = REX12D-TA1-101-CL2 37097 = REX12D-TB1-101-CL2 36970 = REX12D-TA2-101-CL2 37130 = REX22D-TD2-100-CL2 37162 = REX22D-TD2-100 37129 = REX22D-TD1-100 37161 = REX22D-TA1-100 37134 = REX22D-TE2-100 37166 = REX22D-TE2-100-CL2 37194 = REX22D-TD2-101-CL2 37226 = REX22D-TD2-101 37193 = REX22D-TD1-101 37225 = REX22D-TA1-101 37198 = REX22D-TE2-101 37230 = REX22D-TE2-101-CL2 This list may be extended by future circuit protectors.
Hardware version	2 HighByte 3 LowByte	UInt16	0 ... 65535	holds the hardware version of the installed product
Internal assembly order	4 HwHb 5 HwLB 6 LwHB 7 LwLB	UInt32	0 ... 4294967295	holds the assembly order number of the installed product
Production facilities number	8 HwHb 9 HwLB 10 LwHB 11 LwLB	UInt32	0 ... 4294967295	holds the production facilities number of the installed product
Serial number	12 HwHb 13 HwLB 14 LwHB 15 LwLB	UInt32	0 ... 4294967295	holds the serial number of the installed product
Software version (major.x.x)	16	byte	0 ... 255	holds the major software version of the installed product
Software version (x.minor.x)	17	byte	0 ... 255	holds the minor software version of the installed product
Software version (x.x.build)	18	byte	0 ... 255	holds the build software version of the installed product

fig. 19: Device information channel

9.2.3 Configuration data for one channel

The configuration data for one channel consist of 2 bytes.

Access: Index 0x2100 + number of channel, subindex 3

All configuration data with possible conditions are described in the following table.

	byte	type	range	description
Circuit breaker p/n	0 HighByte 1 LowByte	UInt16	0 ... 65535	<p>The expected device type is adjusted here for the channel. The device type always influences a circuit protector, i.e. both possible channels.</p> <p>36873 = REX12D-TA1-100 36874 = REX12D-TA2-100 36878 = REX12D-TE2-100 36910 = REX12D-TE2-100-CL2 36905 = REX12D-TB1-100 36937 = REX12D-TA1-100-CL2 36969 = REX12D-TB1-100-CL2 36906 = REX12D-TA2-100-CL2 36942 = REX12D-TE2-101 36974 = REX12D-TE2-101-CL2 37001 = REX12D-TA1-101 36938 = REX12D-TA2-101 37033 = REX12D-TB1-101 37065 = REX12D-TA1-101-CL2 37097 = REX12D-TB1-101-CL2 36970 = REX12D-TA2-101-CL2 37130 = REX22D-TD2-100-CL2 37162 = REX22D-TD2-100 37129 = REX22D-TD1-100 37161 = REX22D-TA1-100 37134 = REX22D-TE2-100 37166 = REX22D-TE2-100-CL2 37194 = REX22D-TD2-101-CL2 37226 = REX22D-TD2-101 37193 = REX22D-TD1-101 37225 = REX22D-TA1-101 37198 = REX22D-TE2-101 37230 = REX22D-TE2-101-CL2</p> <p>This list may be extended by future circuit protectors.</p>

fig. 20: Configuration data channel

9.2.4 Event message for one channel

The event messages for one channel consist of 1 byte.

Access: Index 0x2100 + number of channel, subindex 4

All event messages with possible conditions are described in the following table.

	byte	type	range	description
Event	0	byte	0 ... 255	<p>bit 0 = waiting for parameterisation bit 1 = reserve bit 2 = new current rating available bit 3 = channel off via momentary switch/switch bit 4 = reserve bit 5 = reserve bit 6 = reserve bit 7 = device error detected</p> <p>»True« means the status is active.</p>

fig. 21: Event messages channel

9.2.5 Action commands for one channel

The action commands for one channel consist of 1 byte.

Access: Index 0x2100 + number of channel, subindex 5

All action commands with possible conditions are described in the following table.

	byte	type	range	description
Action commands	0	byte	0 ... 255	116 = reset trip counter 118 = reset device parameters to factory settings 1) 131 = back to box 2) 192 = reset statistics minimum values 196 = reset statistics maximum values 220 = reset statistics mean values Other values will not be accepted.

fig. 22: Action commands channel

1) The command »118 = reset device parameters to factory settings« within the action commands per channel shall reset the following data:

- parameters (current ratings = 10 A, limit value load current = 80 %) of each channel
- PLC lock bit of each channel (default = True, i.e. channel not to be controlled by the PLC)
- **not** the configured device types
- **not** the statistical values (min, max, avg) of the channels
- **not** the error memory, trip counter and trip reason of the channels

2) The command »131 = back-to-box« within the action commands per channel shall reset the following data:

- Parameters (rated current = 10 A, limit value load current = 80 %) of each channel
- PLC lock bit of each channel (default = True, i.e. channel not controllable by PLC)
- configured device types (default = REX12D-TA1 = 0x9009 = 36873)
- the statistical values (min = 655.35 A/V, max = 0 A V, avg- 0 A/V) of the channel
- the error memory, trip counter and trip reason of the channel

9.2.6 Diagnostic data for one channel

The dynamic information for one channel consists of 22 bytes.

Access: Index 0x2100 + number of channel, subindex 6

All dynamic information with possible conditions is described in the following table.

	byte	type	range	description
Error memory	0 HighByte 1 LowByte	UInt16	0 ... 65535	bit 0 = no parameters available bit 1 = error parameter memory bit 2 = error programme memory bit 3 = error data memory bit 4 = error control unit bit 5 = reset through watchdog bit 6 = reserve bit 7 = reserve bit 8 = reserve bit 9 = reserve bit 10 = reserve bit 11 = reserve bit 12 = reserve bit 13 = reserve bit 14 = reserve bit 15 = reserve »True« means the status is active.
Trip counter	2 HighByte 3 LowByte	UInt16	0 ... 65535	The number of trippings since the last reset of is shown here.
Reason for trip	4	byte	0 ... 255	0 = no trip 1 = short circuit 2 = overload 3 = device temperature too high 4 = internal device failure
Min. Load voltage	5 HighByte 6 LowByte	UInt16	0 ... 65535	Contains the highest measured voltage of the channel since the last reset. A standardised 16-bit-value with a resolution of 10 mV is made available. Example for calculation of the measuring value: value (2512)/100 = ^25.12 Volt
Max. Load voltage	7 HighByte 8 LowByte	UInt16	0 ... 65535	Contains the highest measured voltage of the channel since the last reset. A standardised 16-bit-value with a resolution of 10 mV is made available. Example for calculation of the measuring value: value (2512)/100 = ^25.12 Volt
Medium value Load voltage	9 HighByte 10 LowByte	UInt16	0 ... 65535	Contains the mean voltage value of the channel since the last reset. A standardised 16-bit-value with a resolution of 10 mV is made available. Example for calculation of the measuring value: value (2512)/100 = ^25.12 Volt
Min. load current	11 HighByte 12 LowByte	UInt16	0 ... 65535	Contains the lowest measured current of the channel since the last reset. A standardised 16-bit-value with a resolution of 10 mA is made available. Example for calculation of the measuring value: value (150)/100 = ^1.50 Amps

⋮

	byte	type	range	description
Max. load current	13 HighByte 14 LowByte	UInt16	0 ... 65535	Contains the highest measured current of the channel since the last reset. A standardised 16-bit-value with a resolution of 10 mA is made available. Example for calculation of the measuring value: value (150)/100 = ^1.50 Amps
Medium value load current	15 HighByte 16 LowByte	UInt16	0 ... 65535	Contains the mean current value of the channel since the last reset. A standardised 16-bit-value with a resolution of 10 mA is made available. Example for calculation of the measuring value: value (150)/100 = ^1.50 Amps
Supply voltage/ actuator voltage	17 HighByte 18 LowByte	UInt16	0 ... 65535	Holds the supply voltage / actuator voltage of the channel. A standardised 16-bit-value with a resolution of 10 mV is made available. Example for calculation of the measuring value: value (2512)/100 = ^25.12 Volt
Reserve	19 HighByte 20 LowByte	UInt16	0 ... 65535	reserve
Diagnostic information of the channel	21	byte	0 ... 255	0 = OK 1 = available device type does not match the configured type 2 = no device detected 3 = unused channel 144 = device parameters not plausible 146 = channel off via momentary switch/switch 147 = detected undervoltage 148 = detected excess temperature 149 = reset command required 150 = command was processed correctly 151 = parameterisation required 152 = Internal failure detected 153 = unknown command 154 = set length error 155 = rated current available, check sum error 156 = current rating selector switch was actuated

fig. 23: Dynamic information

10 Appendix

10.1 List of pictures

fig. 1: System overview	6
fig. 2: Dimensions CPC12	7
fig. 3: Status indication and terminals CPC12EC	7
fig. 4: Display status LEDs	9
fig. 5: Display LEDs RJ45 connectors	9
fig. 6: installation drawing	9
fig. 7: EtherCAT object list	15
fig. 8: Cyclical diagnostic data CPC12	16
fig. 9: Total current	16
fig. 10: Input data circuit protector	17
fig. 11: Output data circuit protector	18
fig. 12: Division of parameter index CPC12	19
fig. 13: Division of parameter index channel	19
fig. 14: Device information CPC12	20
fig. 15: Configuration data CPC12	21
fig. 16: Action commands CPC12	22
fig. 17: Dynamic information CPC12	23
fig. 18: Device parameters channel	23
fig. 19: Device information channel	24
fig. 20: Configuration data channel	25
fig. 21: Event messages channel	25
fig. 22: action commands channel	26
fig. 23: Dynamic information	28

10.2 Technical data

For the technical data of CPC12EC please see relevant data sheet.

Notes



Notes

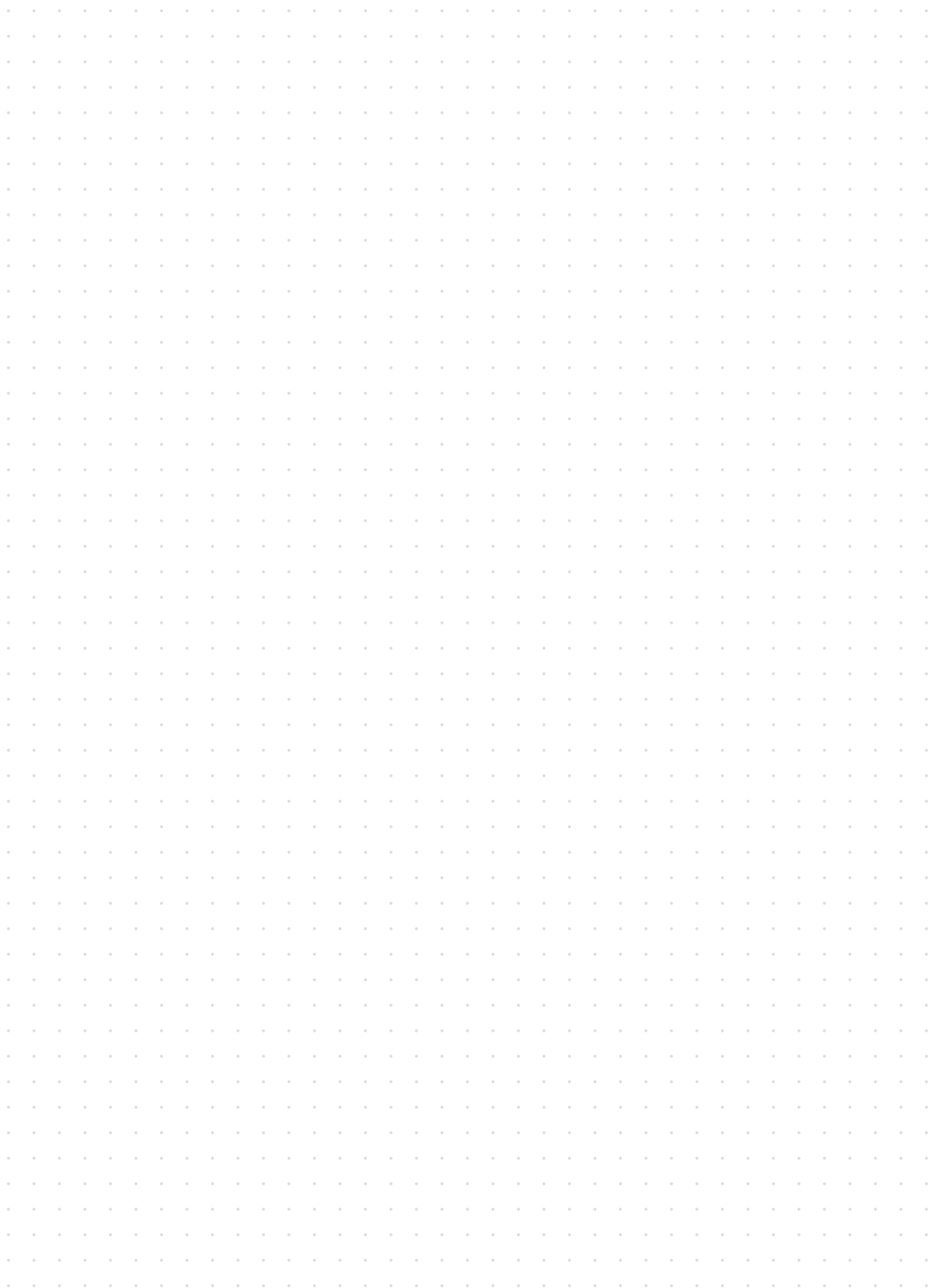



<http://www.e-t-a.de/qr1043/>

Bedienungsanleitung/Instruction manual BA_CPC12EC_Y31350802_ENG_081220
Bestell-Nr./Ref. number Y31350802 - Index: b
Ausgabe/Issue: 12/2020
Alle Rechte vorbehalten/All rights reserved



E-T-A Elektrotechnische Apparate GmbH
Industriestraße 2-8 · 90518 Altdorf
GERMANY
Phone +49 9187 10-0 · Fax +49 9187 10-397
E-mail: info@e-t-a.de · www.e-t-a.de